

Small Geared Motors
with integrated
frequency inverter
Series GF2



Heytraction Antriebstechnik GmbH
Heidemannstraße 3 80939 München

Tel.: +49 89 312135-0
E-Mail: info@heytraction.de

Fax: +49 89 312135-12
Internet: www.heytraction.de

Content

⇒ Technical Data

Generally	3
Characteristics	3
Frequency inverter	3

⇒ Selection Table

GF2 with spur gearbox.....	5
GF2 with spur-bevel gearbox.....	8
GF2 with worm gearbox.....	10

⇒ Dimension Drawings

GF2 with spur gearbox.....	6
GF2 with spur-bevel gearbox.....	9
GF2 with worm gearbox.....	11

This catalog only contains product specifications, but no warranty of characteristics. Delivery opportunities and the right for technical changings are reserved.
All dimensions are indicated in mm.

Please visit our homepage
www.heytraction.de

Generally

The mini geared motors **series GF2** are particularly characterised by their small and compact size and are constructed for industrial applications. In sturdy aluminum cast housings are used recompensed gearings, whereby a very quiet running is ensured. With the high-quality frequency inverter, which is integrated in the motor terminalbox, can be reached a speedrange from 1:6 and by using of a electrical fan cooler 1:120. The speed is adjustabel with a potentiometer, in standard version. The large number of different transmission ratios makes possible a fine gradation of the speed range.

Characteristics

- Simplest start-up with minimum of wiring expenditure
- Small and compact sizes
- Input power 90 Watt
- Output torques up to 30 Nm
- Transmission ratios from $i=2,96$ up to $i=5611$
- Combination with spur-, bevel- and worm gearboxes
- Lubricated for life, thus maintenance-free
- All geared motors are applicable, independent on position. Available mountings see dimensional sketches

Frequency Inverter

Generally

The frequency inverters of the **Series GF2** are intended to change the speed of 3-phase motors from 0 rpm up to a speed with max. 120 Hz, steplessly. It can be hold a constant torque, in the frequency range from 20 up to 85 Hz. With operating outside of this frequency range, it is necessary, to make attitudes on the frequency inverter, or it is to use an additional electrical fan cooler. The inverters are designed for mounting on the motor directly, instead of a terminal box. With using of appropriate seals, it is possible to reach an enclosure up to IP68.

The assembly on the motor is above all favorable, because the electrical connections to the motors are inside the closed metal housing and thus the noise suppression is crucially facilitated.

In addition by being void the motor cable, the electrical installation substantially is more simply and by the omission of the cable capacitances and running times, the energy dissipation of the frequency inverter and the loss of voltage on the inlet are very low. The devices are working with a clock frequency of approx. 10 kHz. Therefore it is possible, to achieve an outstanding quiet running and a running without jerking, also at small numbers of revolutions.

The inverters are appropriate for operation with floating in both directions of rotation. It is possible to brake, up to the energy dissipation of the motor, whereby in braking operation, the motor is operated over-excited (with overvoltage). This means, that the motor energy dissipation in the brake operation will be strongly increased.

Selection of operating mode

Operation mode: Normal operation with potentiometer

The terminal box frequency inverter of the **Series GF2** is supplied in standard version with potentiometer at the terminal box. The led out potentiometer makes possible a free adjusting, in a desired or given frequency range.

Operation mode: Motor potentiometer

The frequency inverter can be adjusted with link plugs and jumper in such a way, that with two tracers the number of revolutions can be set up and/or down. This mode of operation is called motor potentiometer.

Operation mode: Controlling with external tension or a current

The speed can be adjusted by an external voltage signal of $U = 0-10\text{ V}$ or a current of $I = 0-20\text{ mA}$ or $I = 4-20\text{ mA}$

The frequency inverter allways will be delivered in standard version "normal operation with potentiometer".

Please contact us, If the mode of operation should be changed, please because a new adjusting of the jumper and/or link plugs will be necessary.

Electrical connection of the inverter:

Switching example "control with potentiometer in normal operation":

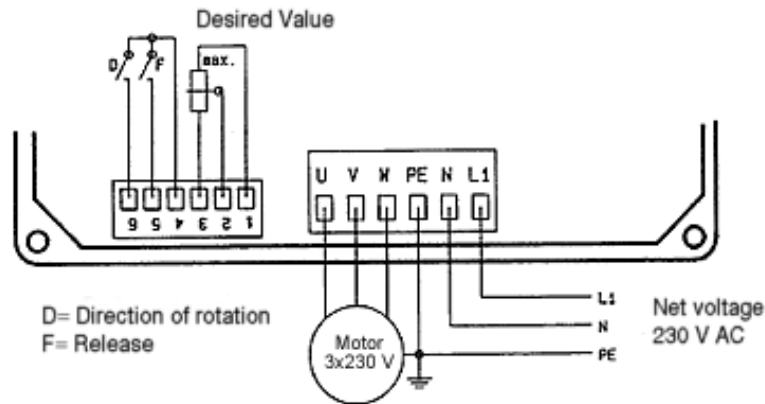

The release of the frequency inverter requires a release on contact 5 in the entrance wiring. Electrical resistance below 1 kOhm are regarded as closed contact. The signal for direction of rotation is set on contact 6. Open signal line means left hand motion. The potentiometer is wired in such a way, as the frequency inverter is supplied in the standard version. The control ports have to be shielded, over a conduit length more than two meters. All control lines are all-insulated against the net and engine lines, after VDE0884.

Technical datas:

Power	0,09 kW
Mains voltage	230 V +/- 15 %
Mains frequency	50 – 60 Hz
Fuse recommended	6,3 A slowly-acting
Motor rated voltage	3 x 230 V
Motor current (30°C)	3 A eff
Motor current (80°C)	2,4 A eff
Operating temperature (housing outside)	0 – 80 °C
Operating temperature, max.	<85 °C
EMV	Industrial class A
Clock frequency	10 kHz
Output frequency	0 – 120 Hz
Frequency min.	0 – 50 % Frequency max.
Ramp time	0,2 – 15 Seconds 4 – 300 Seconds
Desired value	0 – 10 V; 0 – 20 mA; 4 – 20 mA
Input 1	Release
Input 2	Direction of rotation

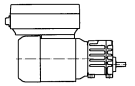

Frequency inverter motor with spur gearbox

Input power 0,09 KW

Range 20 – 120 Hz

Input speed n_2 [rpm], with $f=$			Output torque	Type	Transmission ratio	Weight
20 Hz	50 Hz	120 Hz	T_{2max} [Nm]		i	G [kg]
182	456	1092	1,8	GF21-09/4	2,96	5,5
106	266	636	3,0	GF21-09/4	5,07	5,5
82	205	492	3,9	GF21-09/4	6,58	5,5
68	169	408	4,6	GF22-09/4	8,00	5,9
52	130	312	5,7	GF23-09/4	10,37	5,3
39	98	234	8,0	GF22-09/4	13,71	5,9
30	76	180	10,1	GF22-09/4	17,81	5,9
25	62	150	12,1	GF239-09/4	21,65	6,5
23	57	138	*10	GF23-09/4	23,83	5,3
16	40	96	*10	GF24-09/4	34,15	5,4
14	36	84	20	GF239-09/4	37,1	6,5
12	31	72	*10	GF24-09/4	43,07	5,4
11	28	66	26	GF239-09/4	48,2	6,5
9,2	23	55	*30	GF249-09/4	58,57	6,5
6,8	17	41	*10	GF24-09/4	78,49	5,4
5,4	13,4	32	*30	GF249-09/4	100,38	6,5
4,8	12	29	*10	GF25-09/4	112,5	5,4
4,2	10,4	25	*30	GF249-09/4	130,43	6,5
3,8	9,5	23	*10	GF25-09/4	141,89	5,4
3,4	8,5	20	*30	GF259-09/4	158,5	6,6
2,1	5,2	12,6	*10	GF25-09/4	258,6	5,4
2,0	5,0	12	*30	GF259-09/4	271,62	6,6
1,52	3,8	9,1	*30	GF259-09/4	352,93	6,6
1,44	3,6	8,6	*10	GF26-09/4	370,6	5,5
1,24	3,1	7,4	*30	GF269-09/4	428,87	6,6
1,16	2,9	7,0	*10	GF26-09/4	467,39	5,5
0,72	1,8	4,3	*30	GF269-09/4	734,96	6,6
0,64	1,6	3,8	*10	GF26-09/4	851,7	5,5
0,56	1,4	3,4	*30	GF269-09/4	954,97	6,6
0,44	1,1	2,6	*10	GF27-09/4	1220,79	5,5
0,35	0,88	2,1	*10	GF27-09/4	1539,64	5,5
0,19	0,48	1,14	*10	GF27-09/4	2805,65	5,5

* = constructional maximum torque of the gearbox

Torque characteristic

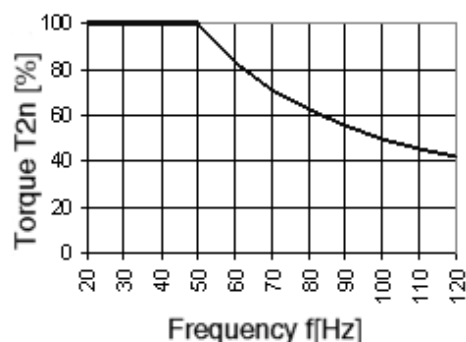

Dimensions

Spur gearbox GF21-09/4

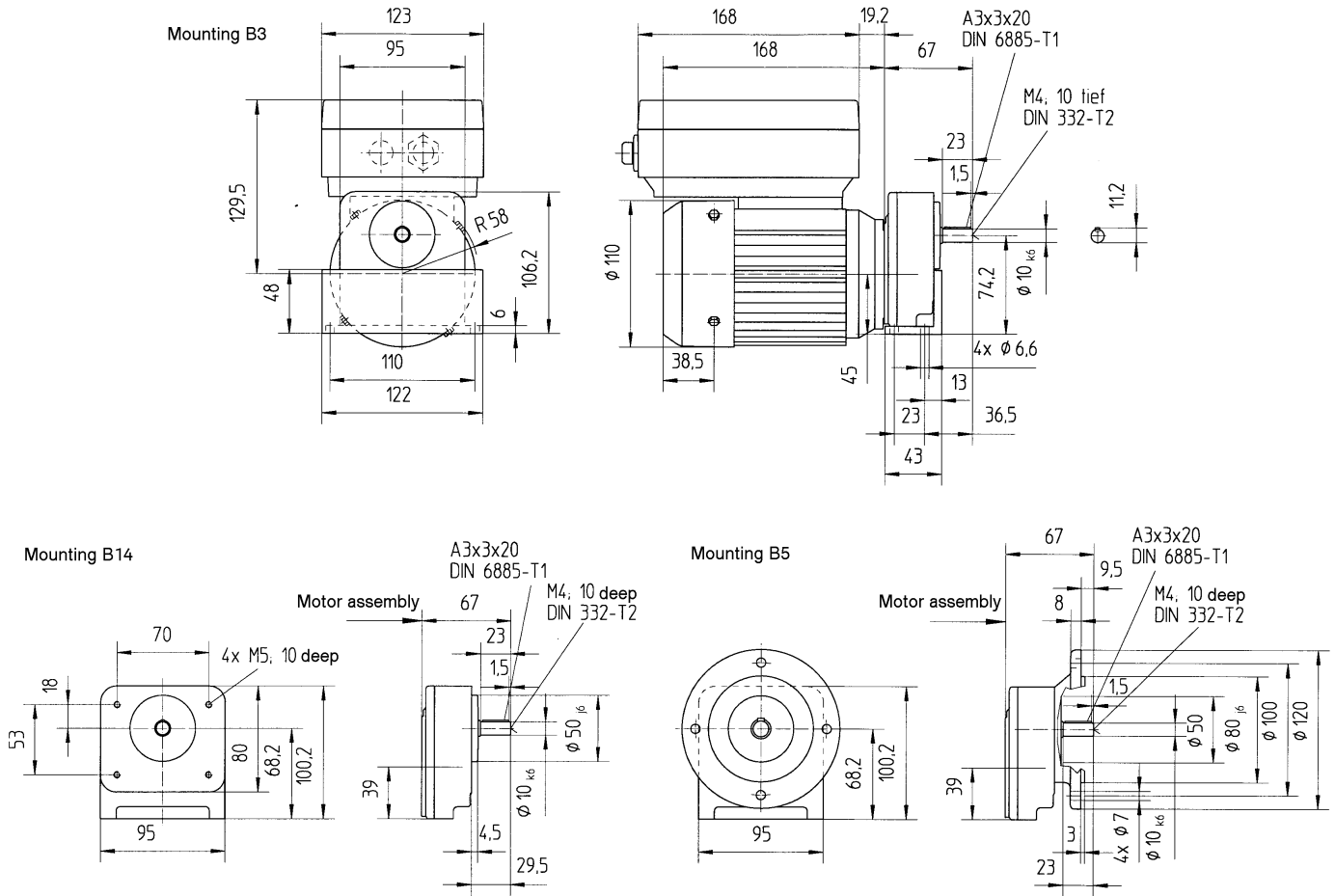

Spur gearbox GF22-09/4

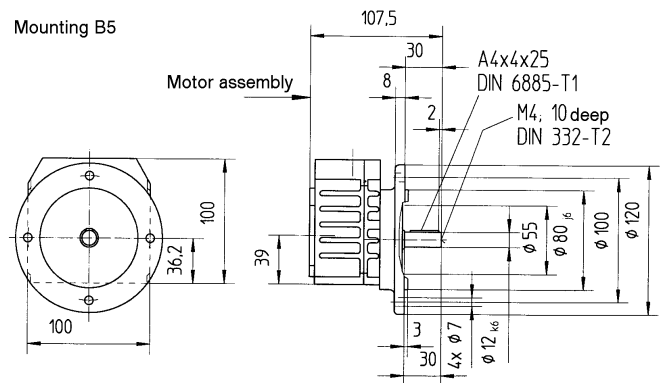
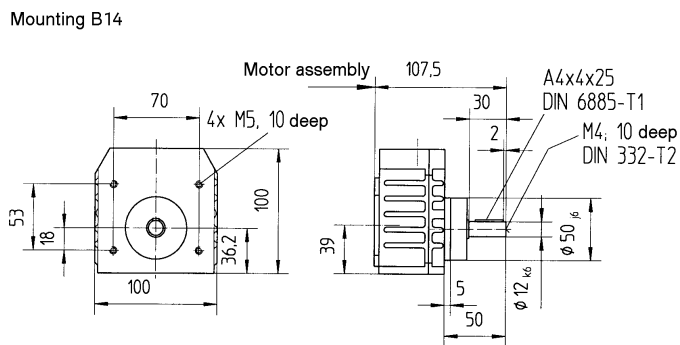
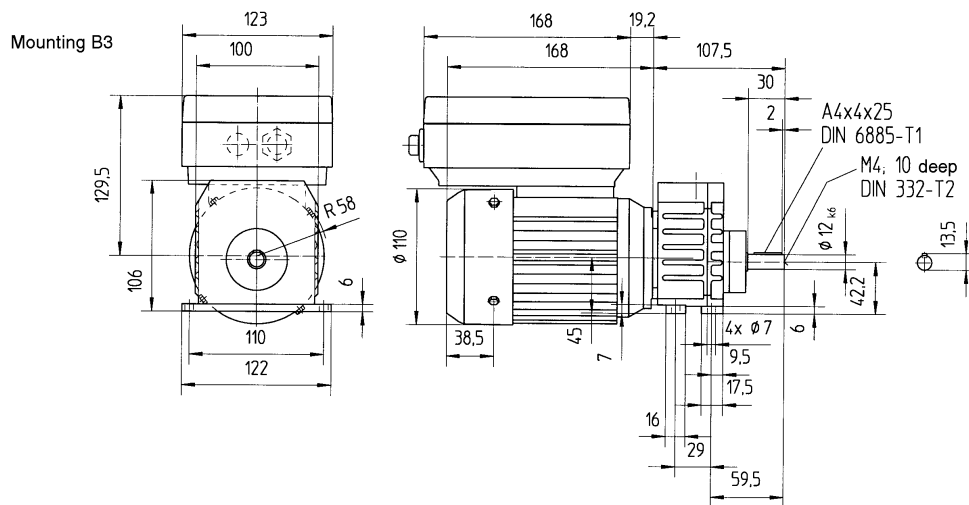

Dimensions

Spur gearbox GF23-09/4 until GF27-09/4

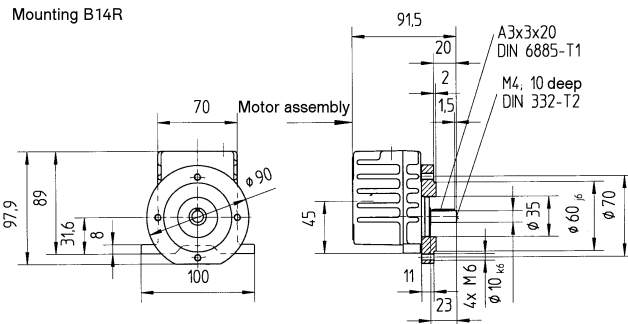
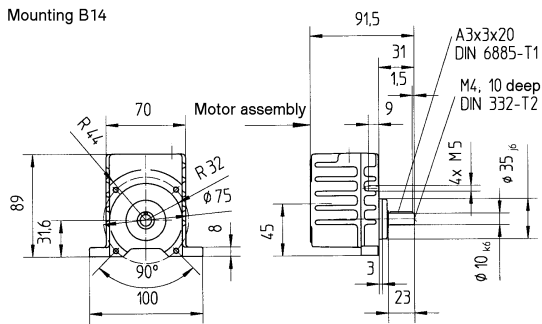
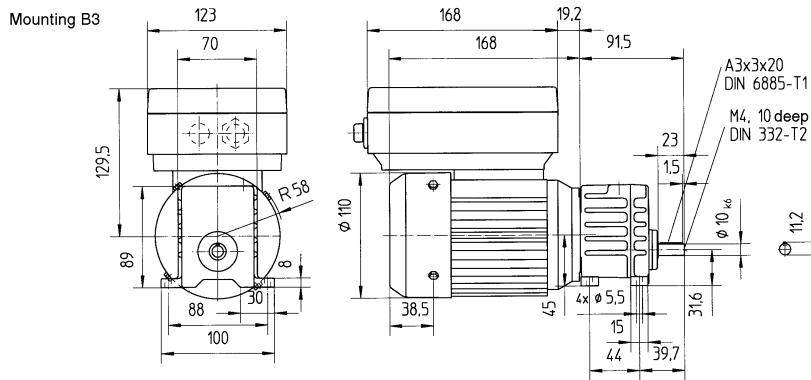

Spur gearbox GF239-09/4 until GF269-09/4

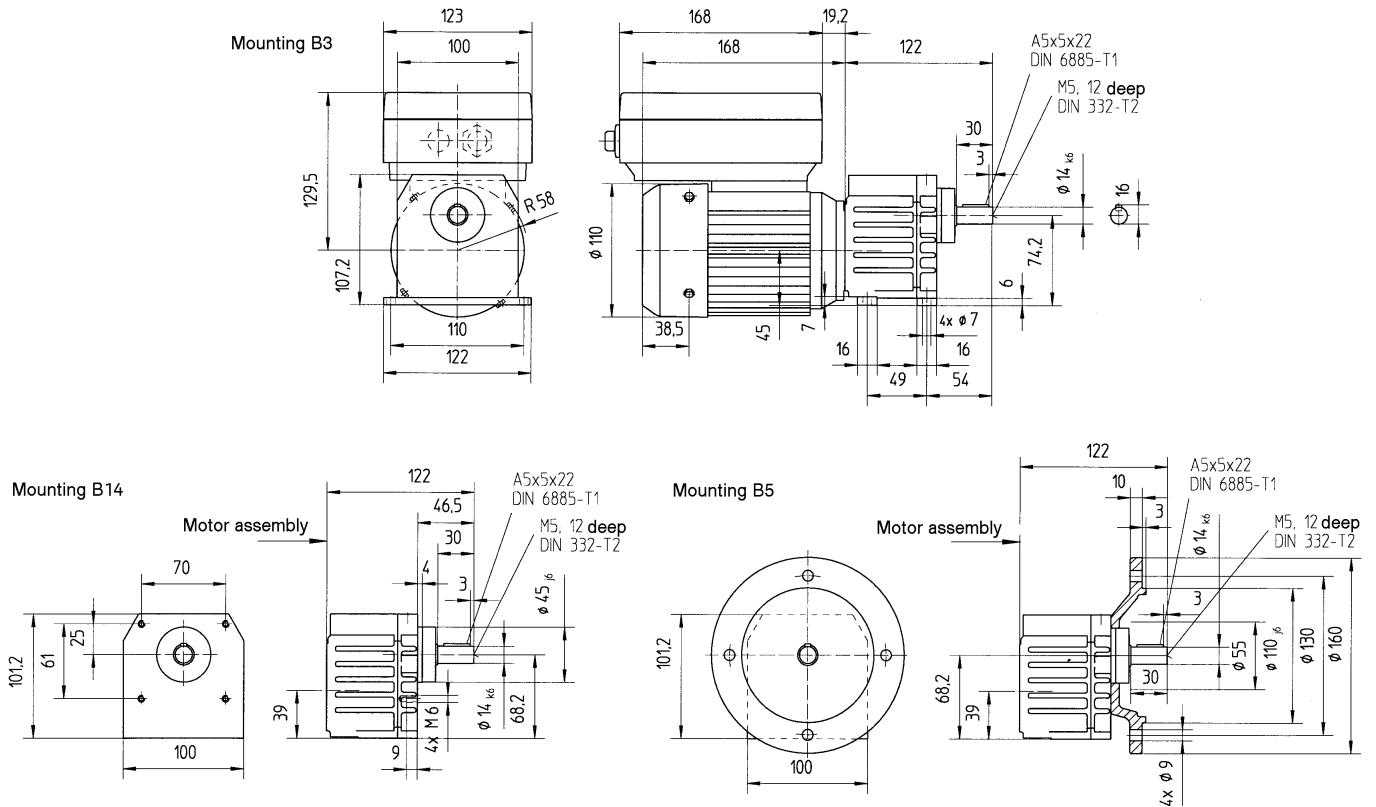

Frequency inverter motor with spur-bevel gearbox

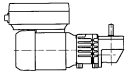

Input power 0,09 KW

Range 20 – 120 Hz

Input speed n_2 [rpm], with $f=$			Output torque	Type	Transmission ratio	Weight
20 Hz	50 Hz	120 Hz	T_{2max} [Nm]		i	G [kg]
81	203	486	3,68	GF23W2-09/4	6,66	6,1
53	133	318	5,6	GF23W2-09/4	10,18	6,1
34	84	203	8,6	GF22W2-09/4	16,00	6,7
26	65	156	11,5	GF23W2-09/4	20,74	6,1
20	49	118	14,8	GF22W2-09/4	27,42	6,7
17	42	100	18,4	GF239W3-09/4	32,47	8,0
15	38	91	*20	GF22W2-09/4	35,63	6,7
11	28	68	*20	GF23W2-09/4	47,65	6,1
9,7	24	58	*30	GF239W3-09/4	55,65	8,0
7,9	20	47	*20	GF24W2-09/4	68,30	6,2
7,5	19	45	*30	GF239W3-09/4	72,30	8,0
6,3	16	38	*20	GF24W2-09/4	86,14	6,2
6,1	15	37	*30	GF249W3-09/4	87,85	8,0
3,6	9	22	*30	GF249W3-09/4	150,57	8,0
3,4	8,6	21	*20	GF24W2-09/4	156,98	6,2
2,8	6,9	17	*30	GF249W3-09/4	195,65	8,0
2,4	6,0	14,4	*20	GF25W2-09/4	225,00	6,2
2,3	5,7	13,6	*30	GF259W3-09/4	237,75	8,1
1,9	4,8	11,4	*20	GF25W2-09/4	283,78	6,2
1,32	3,3	7,9	*30	GF259W3-09/4	407,43	8,1
1,02	2,6	6,1	*30	GF259W3-09/4	529,39	8,1
0,83	2,1	5,0	*30	GF269W3-09/4	643,30	8,1
0,73	1,82	4,4	*20	GF26W2-09/4	741,20	6,3
0,58	1,44	3,5	*20	GF26W2-09/4	934,78	6,3
0,49	1,22	2,9	*30	GF269W3-09/4	1102,44	8,1
0,38	0,94	2,3	*30	GF269W3-09/4	1432,45	8,1
0,22	0,55	1,33	*20	GF27W2-09/4	2441,58	6,3
0,17	0,44	1,05	*20	GF27W2-09/4	3079,28	6,3
0,09	0,24	0,58	*20	GF27W2-09/4	5611,30	6,3

* = constructional maximum torque of the gearbox

Torque characteristic

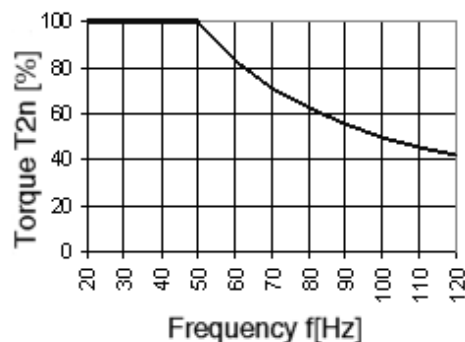

Dimensions

Spur-bevel gearbox GF22W2-09/4

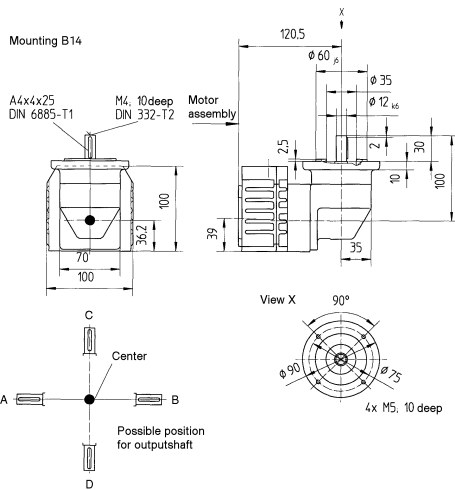
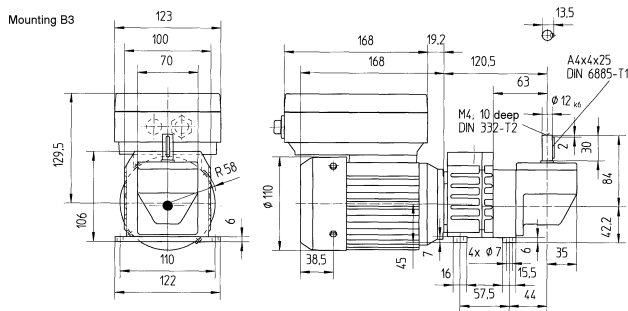

Spur-bevel gearbox GF23W2-09/4 until GF27W2-09/4

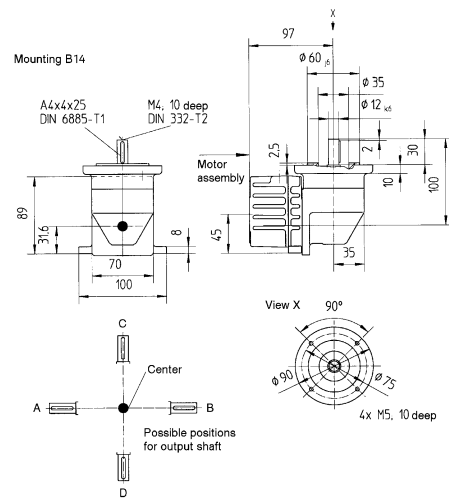
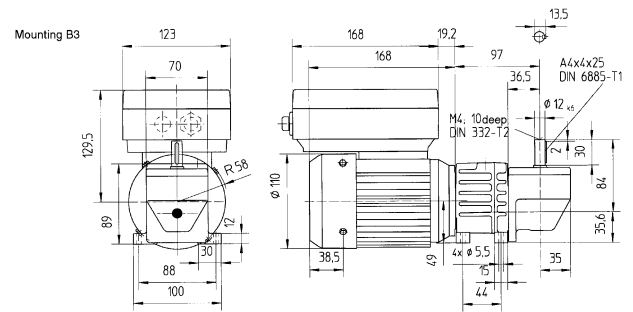

Spur-bevel gearbox GF239W3-09/4 until GF269W3-09/4

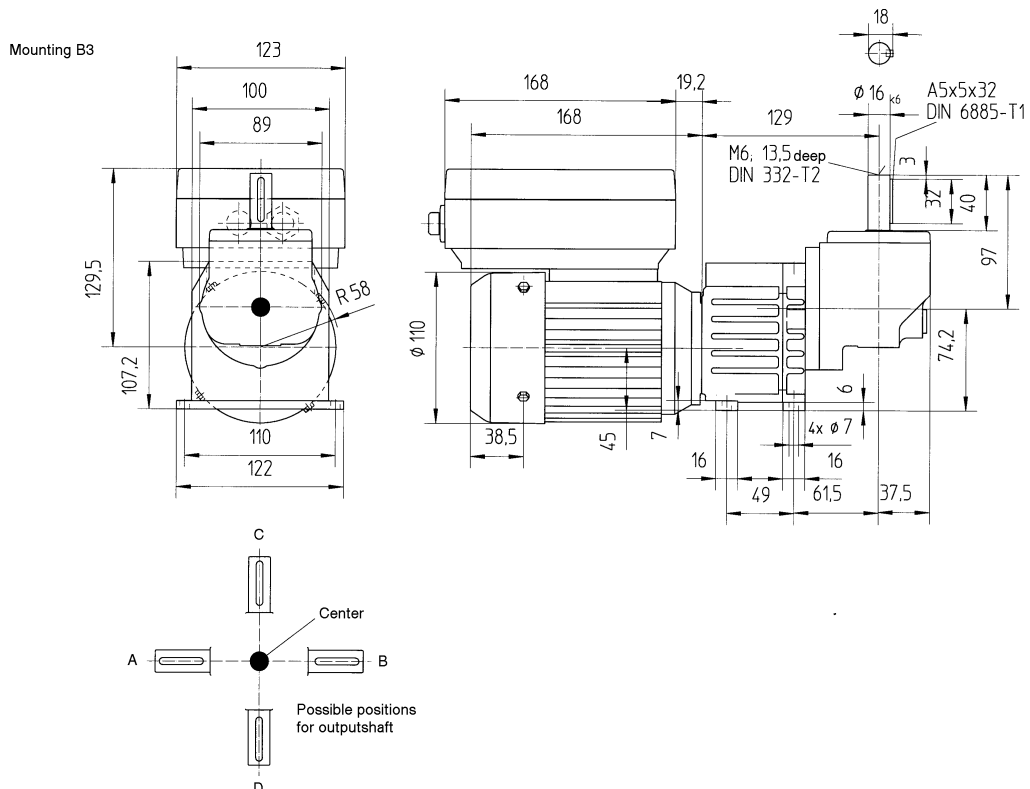

Frequency inverter motor with worm gearbox

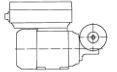

Input power 0,09 KW

Range 20 – 120 Hz

Input speed n_2 [rpm], with $f=$			Output torque	Type	Transmission ratio	Weight
20 Hz	50 Hz	120 Hz	T_{2max} [Nm]		i	G [kg]
80	200	480	3,5	GF2S1-09/4	7	5,3
56	140	336	4,6	GF2S1-09/4	10	5,3
31	78	186	8,1	GF2S1-09/4	18	5,3
23	58	138	8,1	GF2S1-09/4	24	5,3
19	47	114	10	GF2S1-09/4	30	5,3
15	37	90	11	GF2S1-09/4	38	5,3
10	25	60	10	GF2S1-09/4	55	5,3
7,5	19	45	7	GF2S1-09/4	75	5,3
<hr/>						
80	200	480	3,5	GF2S1F-09/4	7	5,7
56	140	336	4,6	GF2S1F-09/4	10	5,7
31	78	186	8,1	GF2S1F-09/4	18	5,7
23	58	138	8,1	GF2S1F-09/4	24	5,7
19	47	114	10	GF2S1F-09/4	30	5,7
15	37	90	11	GF2S1F-09/4	38	5,7
10	25	60	10	GF2S1F-09/4	55	5,7
7,5	19	45	7	GF2S1F-09/4	75	5,7
<hr/>						
112	280	672	2,8	GF2W40-09/4	5	6,8
56	140	336	5,2	GF2W40-09/4	10	6,8
37	93	222	7,4	GF2W40-09/4	15	6,8
30	74	180	8,5	GF2W40-09/4	19	6,8
19	48	114	12	GF2W40-09/4	29	6,8
14	35	84	16	GF2W40-09/4	40	6,8
11	28	66	19	GF2W40-09/4	50	6,8
9	22	54	23	GF2W40-09/4	65	6,8
7	17	42	27	GF2W40-09/4	80	6,8

Torque characteristic

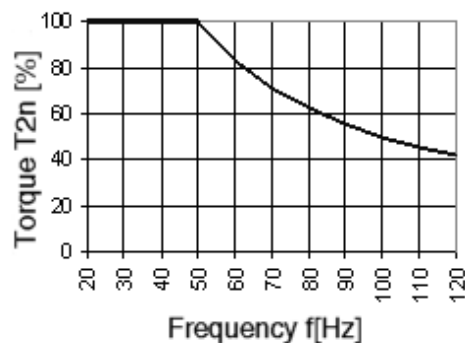

Dimensions

Worm gearbox GF2S1-09/4

Mounting B3
outputshaft both sides

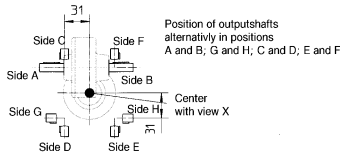
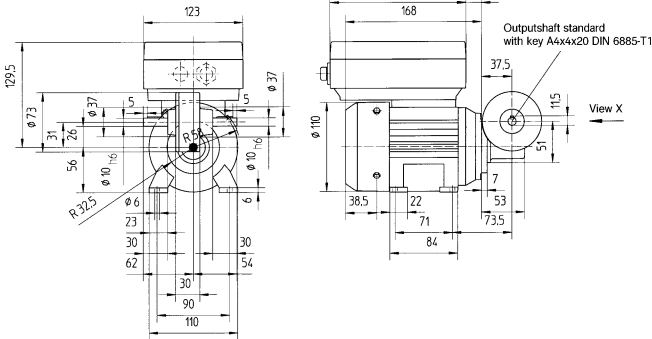

Worm gearbox GF2S1F-09/4

Mounting B5
single outputshaft

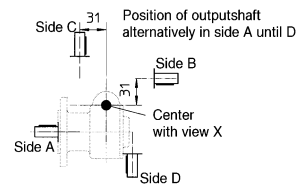
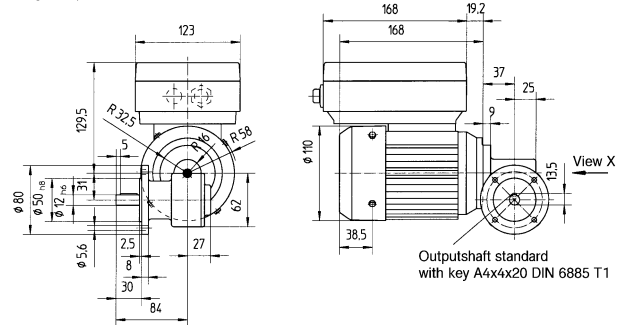

Worm gearbox GF2W40-09/4

Mounting B3
for hollow- and solidshaft

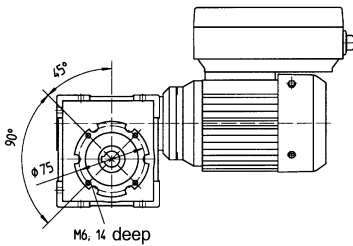

Hollowshaft
both sides

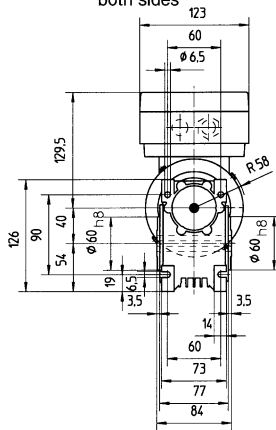

Torque bracket
for hollow- and solidshaft

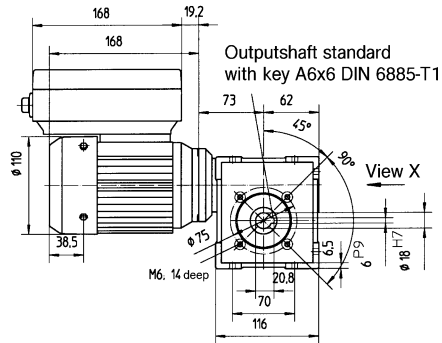
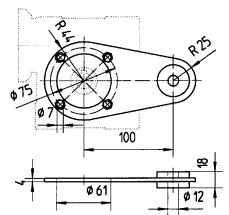

Hollowshaft double side

Position of outputshaft
alternatively side A until D

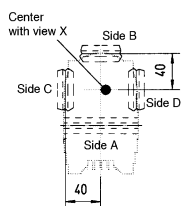

Hollowshaft single side

Position of outputshaft
alternatively side A until D

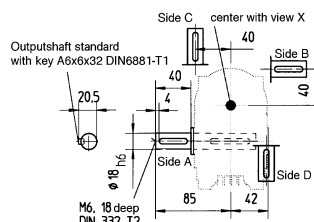

Solidshaft both sides

Position of outputshafts
alternatively in Side
A and B; G and H; C and D; E and F

