

Anordnung Motor-Klemmenkasten
 A-D wahlweise (C=Standard)
 Arrangement of motor terminal boxes
 A-D optionally (C = standard)

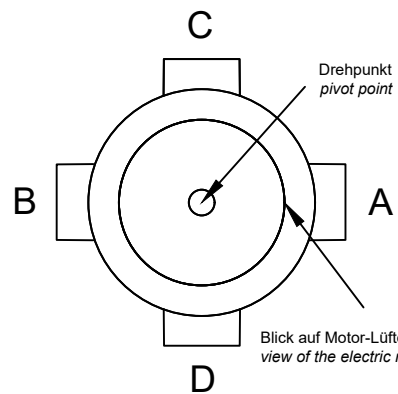

Anordnung Getriebe-Abtriebswelle
 A-D wahlweise (C=Standard)
 Arrangement of gearbox output shaft
 A-D optionally (C = standard)

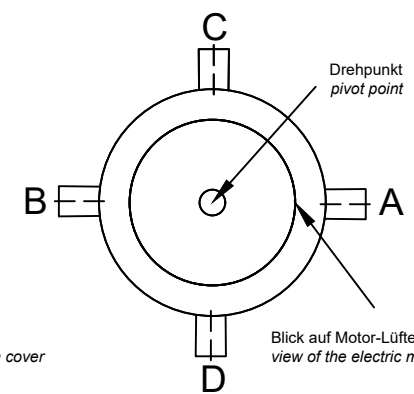

Blick auf Motor-Lüfterhaube
 view of the electric motor fan cover

Blick auf Motor-Lüfterhaube
 view of the electric motor fan cover

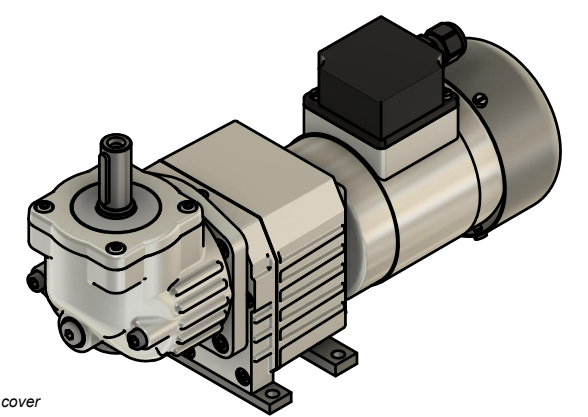

16k6	+0,001	+0,012
Toleranzen / Tolerances		

Projection ISO 5456-2
 Allg. Toleranzen nach /
 General tolerances according to
 ISO 2768-m

Elektromotoren sind Zukaufteile. Maße können daher abweichen. Alle Maßangaben ohne Gewähr.
 Electric motors are purchased parts. Dimensions can therefore differ. All dimensions without guarantee.



heytraction
 Antriebstechnik GmbH
 Heidemannstraße 3
 DE-80939 München
 www.heytraction.de

Stirn-Kegelrad Getriebemotor 0,03 kW Spur bevel geared motor 0,03 kW Bauform / mounting B3	
Benennung / Designation G239W3_G269W3-03-4_B3_KK_C_WE_C	
Zeichnungsnummer / Drawing number MZ22019331	Maßstab / Scale 1:2 Maße in mm Dimensions in mm
Erstellt mit CAD-Software Fusion 360	Ausgabedatum Format A3 Blatt 1/1