

1 2 3 4 5 6 7 8

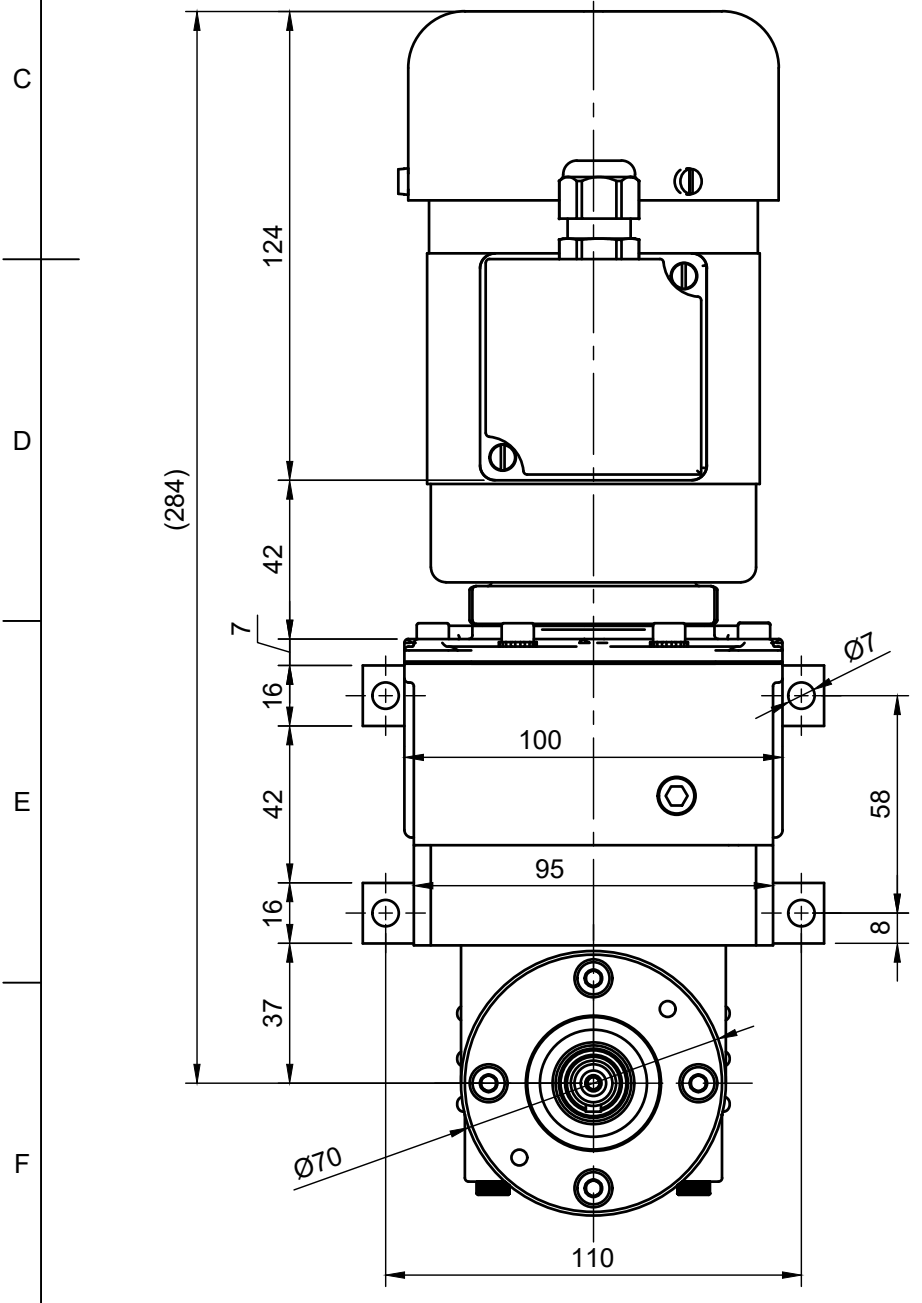

Anordnung Motor-Klemmenkasten
A-D wahlweise (C=Standard)
Arrangement of motor terminal boxes
A-D optionally (C = standard)

Anordnung Getriebe-Abtriebswelle
A-D wahlweise (C=Standard)
Arrangement of gearbox output shaft
A-D optionally (C = standard)

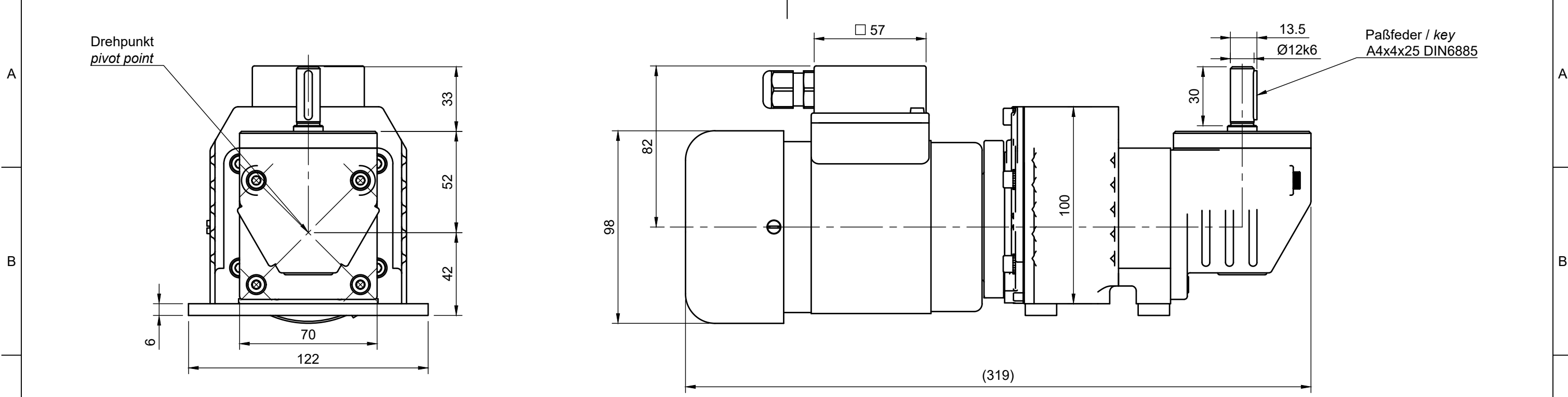
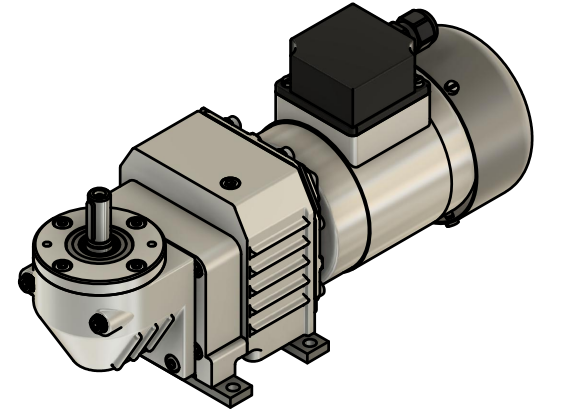
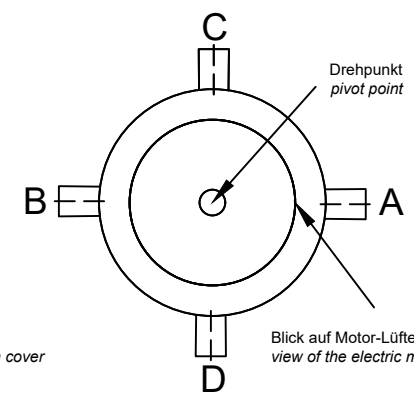
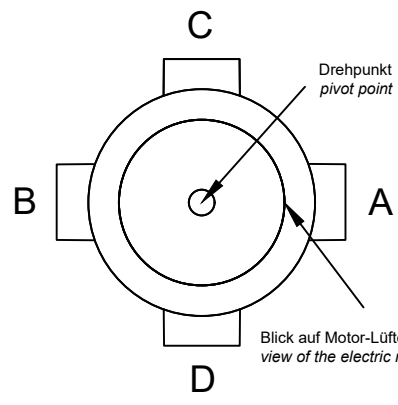

12k6	+0,001	+0,012
Toleranzen / Tolerances		

Projection ISO 5456-2
Allg. Toleranzen nach /
General tolerances according to
ISO 2768-m

Elektromotoren sind Zukaufteile. Maße können daher
abweichen. Alle Maßangaben ohne Gewähr.
Electric motors are purchased parts. Dimensions can
therefore differ. All dimensions without guarantee.



heytraction
Antriebstechnik GmbH
Heidemannstraße 3
DE-80939 München
www.heytraction.de

Stirn-Kegelrad Getriebemotor 0,03 kW Spur bevel geared motor 0,03 kW Bauform / mounting B3	
Benennung / Designation G22W2-03-4_B3_KK_C_WE_C	
Zeichnungsnummer / Drawing number MZ22019311	Maßstab / Scale 1:2 Maße in mm Dimensions in mm
Erstellt mit CAD-Software Fusion 360	Ausgabedatum Format A3 Blatt 1/1

1 2 3 4 5 6 7 8