

1 2 3 4 5 6 7 8

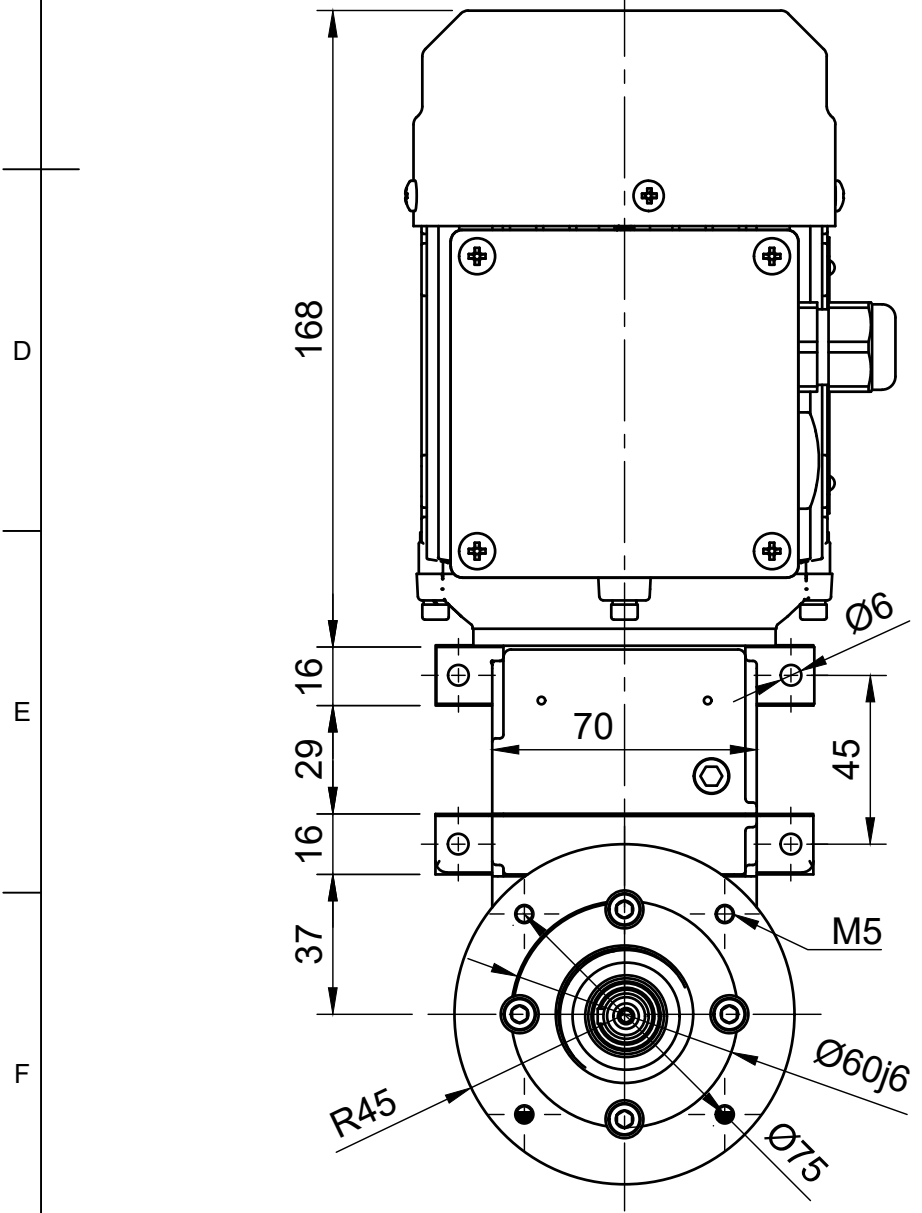

Anordnung Motor-Klemmenkasten  
A-D wahlweise (C=Standard)  
Arrangement of motor terminal boxes  
A-D optionally (C = standard)

Anordnung Getriebe-Abtriebswelle  
A-D wahlweise (C=Standard)  
Arrangement of gearbox output shaft  
A-D optionally (C = standard)

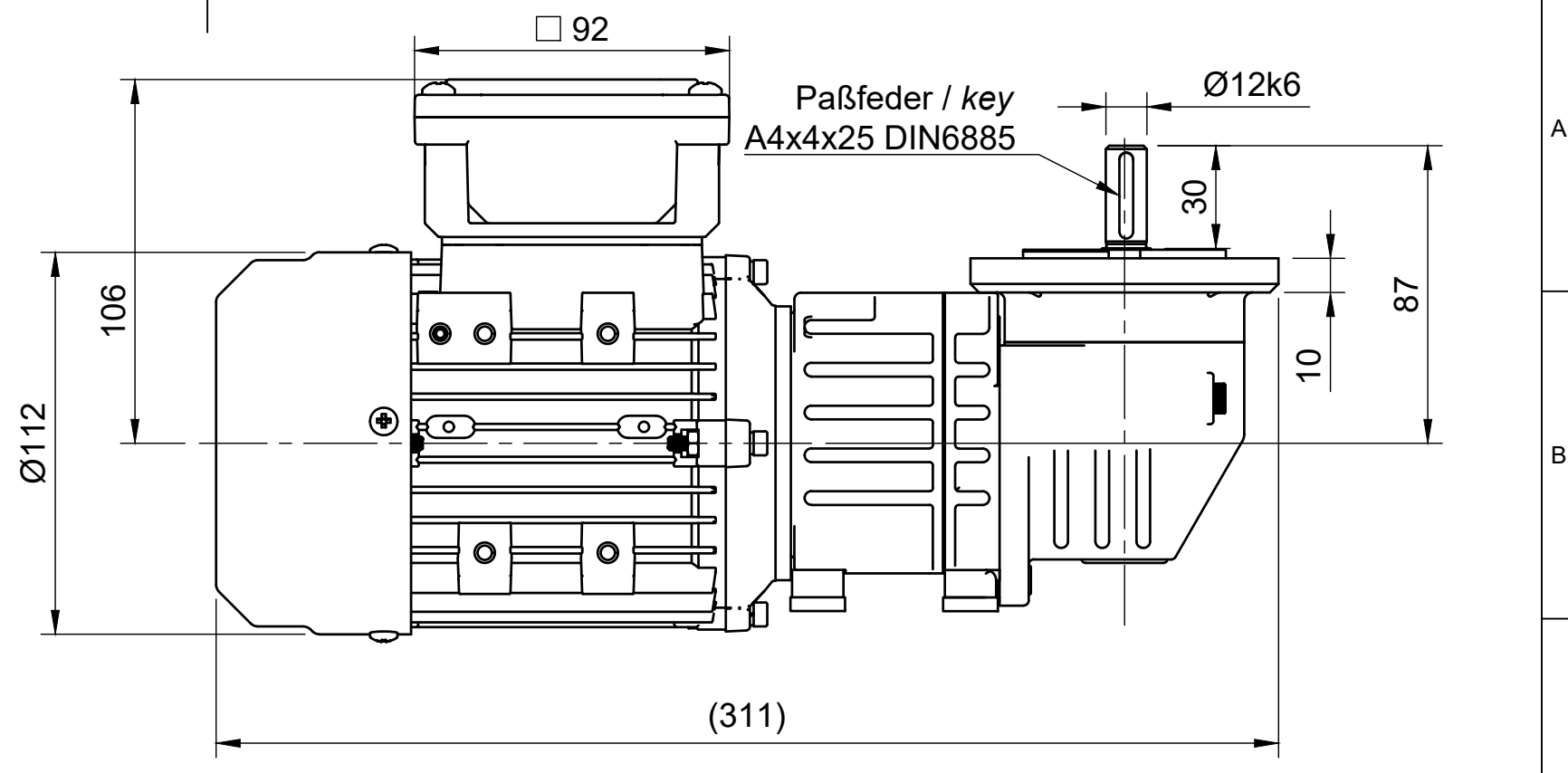
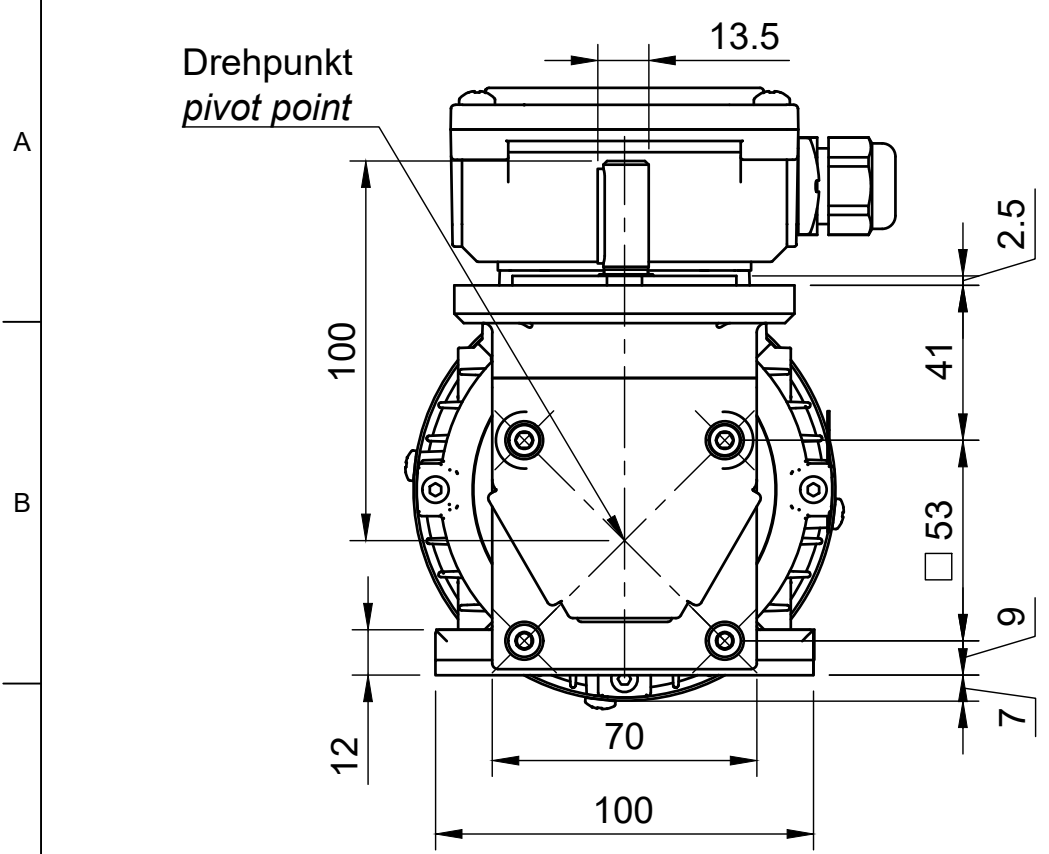
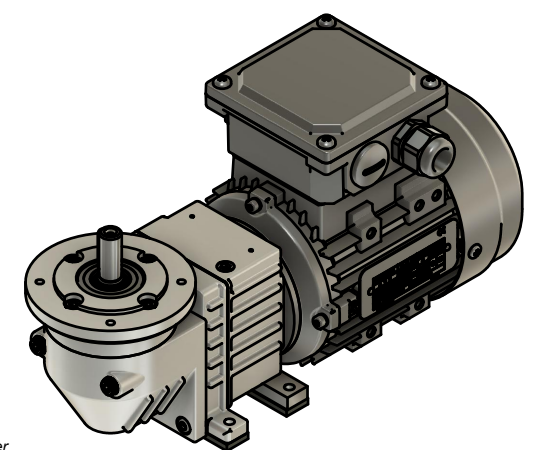
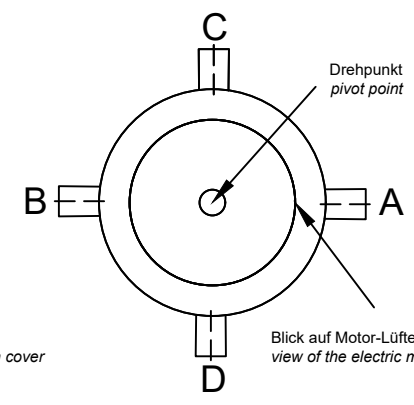
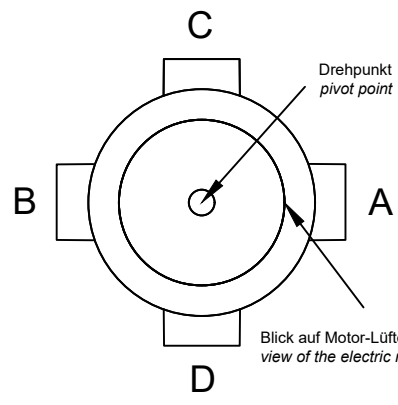

60j6	-0,007	+0,012
12k6	+0,001	+0,012

Toleranzen / Tolerances

Projection ISO 5456-2  
Allg. Toleranzen nach /  
General tolerances according to  
ISO 2768-m

Elektromotoren sind Zukaufteile. Maße können daher  
abweichen. Alle Maßangaben ohne Gewähr.  
Electric motors are purchased parts. Dimensions can  
therefore differ. All dimensions without guarantee.

heytraction  
Antriebstechnik GmbH  
Heidemannstraße 3  
DE-80939 München  
www.heytraction.de

Stirn-Kegelrad Getriebemotor 0,09 kW Spur bevel geared motor 0,09 kW Bauform / mounting B3/B14	
Benennung / Designation <b>G23W2_G27W2-09-4_B3B14_KK_C_WE_C</b>	
Zeichnungsnummer / Drawing number <b>MZ22019025</b>	Maßstab / Scale 1:2 Maße in mm Dimensions in mm
Erstellt mit CAD-Software Fusion 360	Ausgabedatum Format A3 Blatt 1/1

1 2 3 4 5 6 7 8