

Anordnung Motor-Klemmenkasten
 A-D wahlweise (C=Standard)
 Arrangement of motor terminal boxes
 A-D optionally (C = standard)

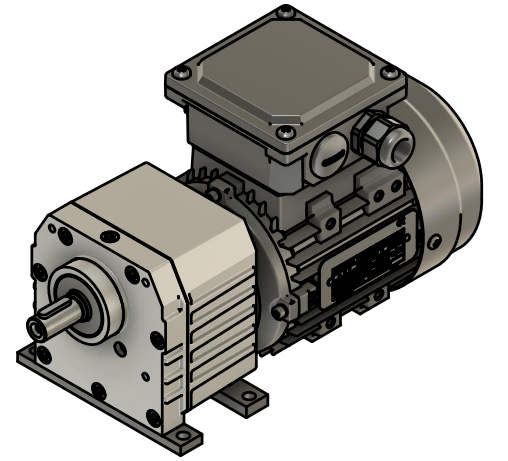
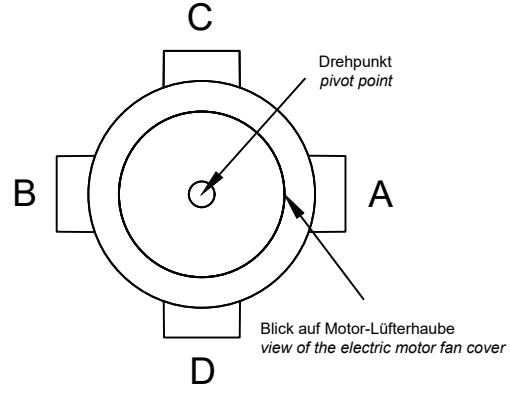

45j6	-0,005	+0,011
14k6	+0,001	+0,012

Toleranzen / Tolerances

Projection ISO 5456-2
 Allg. Toleranzen nach /
 General tolerances according to
 ISO 2768-m

Elektromotoren sind Zukaufteile. Maße können daher abweichen. Alle Maßangaben ohne Gewähr.
 Electric motors are purchased parts. Dimensions can therefore differ. All dimensions without guarantee.



heytraction
 Antriebstechnik GmbH
 Heidemannstraße 3
 DE-80939 München
 www.heytraction.de

Stirnrad-Getriebemotor / Spur Geared Motor
 P= 0,09 kW, Bauform / mounting B3 + B3/B14

Benennung / Designation
G239_G269-09-4_B3_B3B14_KK_C

Zeichnungsnummer / Drawing number MZ22053010	Maßstab / Scale 1:2 Maße in mm Dimensions in mm
Erstellt mit CAD-Software Fusion 360	Ausgabedatum Format A3 Blatt 1/1