

Anordnung Motor-Klemmenkasten  
 A-D wahlweise (C=Standard)  
 Arrangement of motor terminal boxes  
 A-D optionally (C = standard)

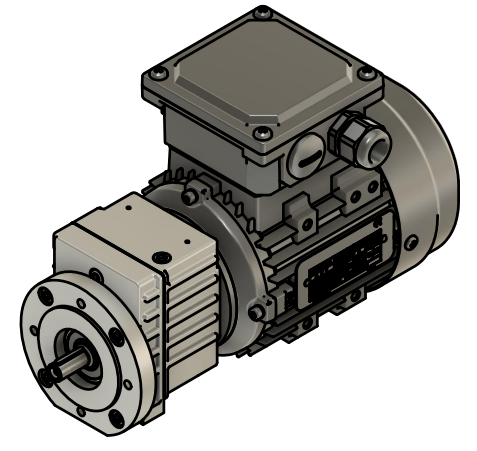

60j6	-0,007	+0,012
10k6	+0,001	+0,010

Toleranzen / Tolerances

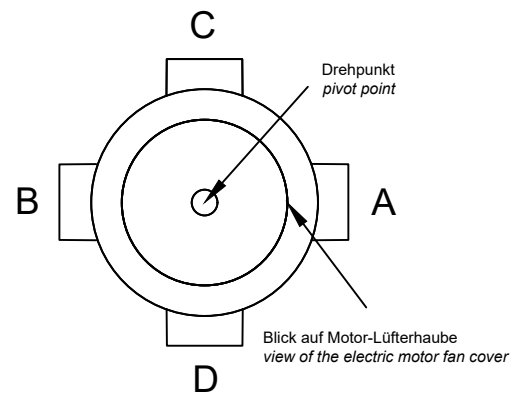
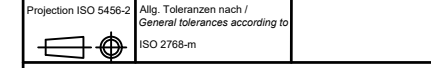

Elektromotoren sind Zukaufteile. Maße können daher abweichen. Alle Maßangaben ohne Gewähr.  
 Electric motors are purchased parts. Dimensions can therefore differ. All dimensions without guarantee.



heytraction  
 Antriebstechnik GmbH  
 Heidemannstraße 3  
 DE-80939 München  
 www.heytraction.de

Stirnrad-Getriebemotor / Spur Geared Motor  
 P= 0,09 kW, Bauform / mounting B14R

Benennung / Designation  
**G23\_G27-09-4\_B14R\_KK\_C**

Zeichnungsnummer / Drawing number  
**MZ22013030**

Maßstab / Scale 1:2	Ausgabedatum Format Blatt 1/1
Maße in mm Dimensions in mm	

Erstellt mit CAD-Software Fusion 360