

Anordnung Motor-Klemmenkasten  
 A-D wahlweise (C=Standard)  
 Arrangement of motor terminal boxes  
 A-D optionally (C = standard)

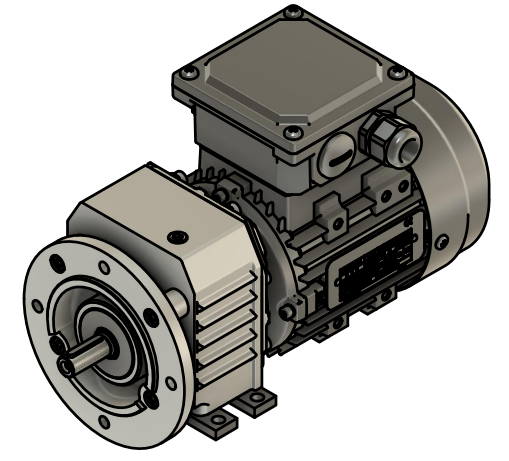
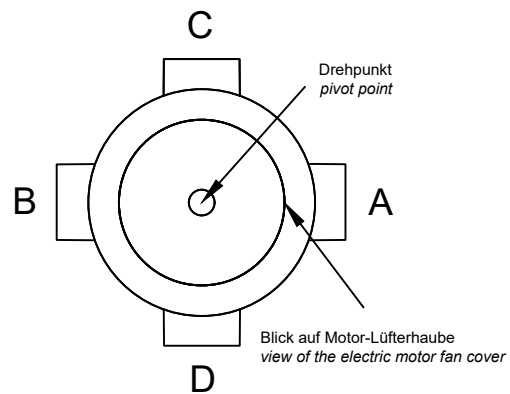

80j6	-0,007	+0,012
12k6	+0,001	+0,012
Toleranzen / Tolerances		

Projection ISO 5456-2  
 Allg. Toleranzen nach /  
 General tolerances according to  
 ISO 2768-m

Elektromotoren sind Zukaufteile. Maße können daher abweichen. Alle Maßangaben ohne Gewähr.  
 Electric motors are purchased parts. Dimensions can therefore differ. All dimensions without guarantee.



heytraction  
 Antriebstechnik GmbH  
 Heidemannstraße 3  
 DE-80939 München  
 www.heytraction.de

Stirnrad-Getriebemotor / Spur Geared Motor  
 P= 0,09 kW, Bauform / mounting B3/B5

Benennung / Designation  
**G22-09-4\_B3B5\_KK\_C**

Zeichnungsnummer / Drawing number  
**MZ22012050**

Maßstab / Scale  
 1:2  
 Maße in mm  
 Dimensions in mm

Erstellt mit CAD-Software Fusion 360  
 Ausgabedatum  
 Format A3  
 Blatt 1/1