

Actuator

Series K



Heytraction Driving Technology GmbH
Heidemannstraße 3 80939 Munich

Phone: +49 89 312135-0 Fax: +49 89 312135-12
Email: info@heytraction.de Internet: www.heytraction.de

Table of contents

Catalogue K 01/96

⇒ Technical Overview

Function	3
Drive-side and output-side attachments	3
Control devices	4
Type designation	5
Types	5

⇒ Selection tables

K2 with spur gear	6
K2 with spur and bevel gear	8
K2 with worm gear	9

⇒ Dimensional drawings

K2 with free drive shaft	10
K2 with motor	10
K2 with spur gear	10
K2 with spur and bevel gear	12
K2 with worm gear	12

This catalogue contains product specifications,
but no assurance of properties.
We reserve the right for technical changes and changes of availability.
All dimensions are given in mm.

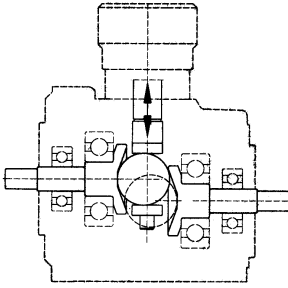

- Drive power = 0.18 kW
- Output torques up to 70 Nm
- Output speeds from 0.13 to 4,200 1/min
- Adjusting range 1: 9
- Adjustment option at standstill
- Consistent speed, quiet running, long life and high efficiency
- Lifetime lubrication means maintenance-freedom
- Completely closed design, all of the transmission parts running in oil bath, thereby suitable for use in hazardous areas

Function

Two axially parallel hollow cones enclose a steel ball under prestressing. The ball moves along the hollow cones on an almost punctiform contact area, transmitting the power from the drive shaft to the output shaft in the same direction. The direction of rotation is arbitrary. A sliding ball guide at the control device steplessly varies the transmission ratio between the input and output shafts. Thus, an adjusting range between 3:1 and 1:3 is possible (total R = 9). Speed is set using an adjustment screw; it takes 10 turns to traverse the entire adjusting range.

Drive-side attachments

Free drive shaft

In this version maximum drive speed at continuous operation must not exceed 2000 1/min. Permissible radial load in the drive shaft is 44 N.

Motor mounting

Powered by a B14 standard motor. Standard version includes either 4-pole three-phase AC motors, three-phase explosion-proof motors or single phase AC motors.

Output-side attachments

The following devices can be attached to adjust the output speed to requirements:

- Spur gear units, 1 to 7 steps
- Spur and bevel gears
- Worm gears

Control devices

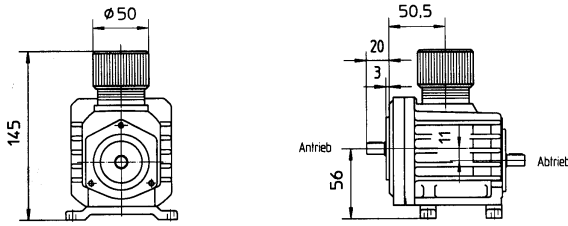

Default control device

The entire adjusting range is traversed by 10 turns of the handwheel. The control sleeve is provided with a linear 1-10 scale, yet with no direct relation to the output speed, since the control curve is approximately logarithmic.

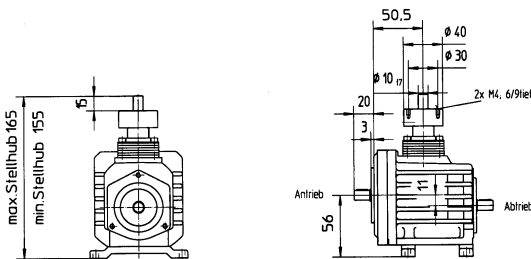

Control device II

Using rigid or flexible shafts, this version with a free adjusting shaft is used for extending the control device; sprockets or the like can also be used. Travel is 10 mm, the required torque approximately 1.3 nm.

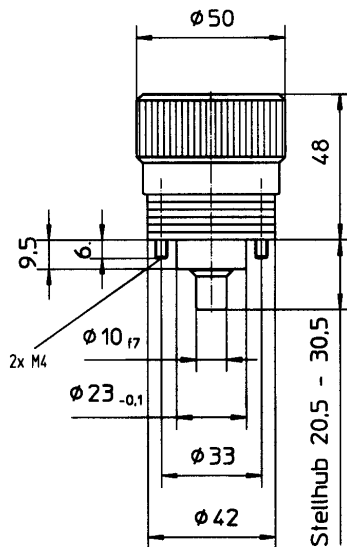

Attached control device

Together with control device II and the corresponding shaft extension, mechanical remote adjustment is possible with series K actuators.

K2 designs according to DIN 42950

Fußausführung

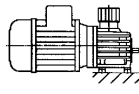

B3

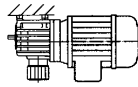

B8



B6



B7

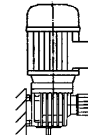

V5

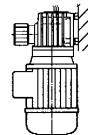

V6

Flanschausführung

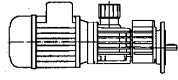

B5

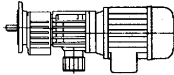

B8/B5 o.Füße



B6/B5
ohne Füße



B7/B5
ohne Füße

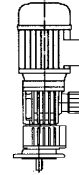

V1

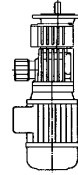

V3

Flanschausführung

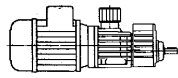

B14

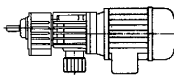

B8/B14 o.Füße



B6/B14
ohne Füße



B7/B14
ohne Füße

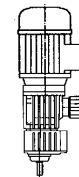

V18

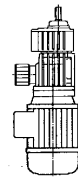

V19

Klemmenkastenordnung

normal C

Anordnung A, B, D auf Wunsch
 Die Bezeichnungen beziehen sich auf
 Blickrichtung Lüfterhaube und Getriebe
 in Normallage.

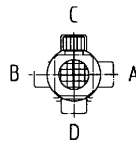

Type designation

K2 69 W3 - 18/4

Series

K2

Actuator, freely adjustable

Reduction gear unit

1	1-step spur gear
2	2-step spur gear
3-7	3- to 7-step spur gear
39-69	3- to 6-step spur gear
40-60	4- to 6-step spur gear
S1	1-step worm gear

Spiral bevel gear

W2	20 Nm
W3	30 Nm

Motor

18/4

0.18 KW, 4-pole, three-phase or 1-phase AC

Actuator with spur gear

Series K

Driving power
0.18 KW

Adjusting range
1:9

Output speeds n_2 at $n_1 = 1400$ 1/min	Output torque M_2	Type	Gearing ratio	Appr. weight w motor	Appr. weight w/o motor	Dimensions
1/min	Nm		i =	kg	kg	Fig. no.
465 - 4200	0.9 - 0.27	K2-18/4	-----	5.8	1.8	2
155 - 1400	2.5 - 0.75	K21-18/4	3	6.8	2.8	3
111 - 996	3.4 - 1.02	K23-18/4	4.2	6.6	2.6	5
92 - 824	4.3 - 1.3	K21-18/4	5.1	6.8	2.8	3
71 - 640	5.6 - 1.7	K21-18/4	6.6	6.8	2.8	3
58 - 522	6.6 - 2.0	K22-18/4	8.0	7.3	3.3	4
45 - 405	8.4 - 2.5	K23-18/4	10.4	6.6	2.6	5
34 - 306	11.2 - 3.3	K22-18/4	13.7	7.3	3.3	4
30 - 268	*10 - 3.8	K23-18/4	15.6	6.6	2.6	5
26 - 234	14.6 - 4.3	K22-18/4	17.8	7.3	3.3	4
22 - 194	17.2 - 5.1	K239-18/4	21.6	7.8	3.8	6
21 - 188	*10 - 5.3	K24-18/4	22.3	6.7	2.7	5
16.5 - 149	*10 - 6.7	K24-18/4	28	6.7	2.7	5
13.7 - 123	*10 - 8.3	K24-18/4	34	6.7	2.7	5
12.6 - 113	29 - 8.5	K239-18/4	37	7.8	3.8	5
10.8 - 97	*10 - *10	K24-18/4	43	6.7	2.7	6
9.7 - 87	*30 - 11.5	K239-18/4	48	7.8	3.8	6
9 - 81	*10 - *10	K24-18/4	51.3	6.7	2.7	5
8 - 72	*30 - 13.7	K249-18/4	59	7.8	3.8	6
8 - 72	48 - 13.7	K240-18/4	59	9.3	5.3	7
5.9 - 53	*10 - *10	K24-18/4	78	6.7	2.7	5
5 - 45	*10 - *10	K25-18/4	93	6.7	2.7	5
4.7 - 42	*30 - 23	K249-18/4	100	7.8	3.8	6
4.7 - 42	*70 - 23	K240-18/4	100	9.3	5.3	7
4.1 - 37	*10 - *10	K25-18/4	112	6.7	2.7	5
3.5 - 31	*30 - *30	K249-18/4	130	7.8	3.8	6
3.5 - 31	*70 - 31	K240-18/4	130	9.3	5.3	7
3.3 - 30	*10 - *10	K25-18/4	142	6.7	2.7	5
3 - 27	*30 - *30	K259-18/4	158	7.9	3.9	6
3 - 27	*70 - 37	K250-18/4	158	9.5	5.5	7
2.8 - 25	*10 - *10	K25-18/4	169	6.7	2.7	5
1.9 - 17.3	*10 - *10	K26-18/4	242	6.8	2.8	5
1.7 - 15	*30 - *30	K259-18/4	272	7.9	3.9	6
1.7 - 15	*70 - 64	K250-18/4	272	9.5	5.5	7
1.5 - 13.2	*10 - *10	K26-18/4	305	6.8	2.8	5
1.3 - 12	*30 - *30	K259-18/4	353	7.9	3.9	6
1.3 - 12	*70 - *70	K250-18/4	353	9.5	5.5	7
1.26 - 11.3	*10 - *10	K26-18/4	371	6.8	2.8	5

* Design-related permissible torque of transmission gear

Actuator with spur gear

Series K

Driving power
0.18 KW

Adjusting range
1:9

Output speed n_2 at $n_1 = 1400$ 1/min	Output torque M_2	Type	Gearing ratio	Appr. weight w motor	Appr. weight w/o motor	Dimensions
1/min	Nm		$i =$	kg	kg	Fig. no.
1.1 - 10	*30 - *30	K269-18/4	429	7.9	3.9	6
1.1 - 10	*70 - *70	K260-18/4	429	5.7	5.7	7
1.0 - 9.0	*10 - *10	K26-18/4	467	6.8	2.8	5
0.8 - 7.5	*10 - *10	K26-18/4	556	6.8	2.8	5
0.63 - 5.7	*30 - *30	K269-18/4	735	7.9	3.9	6
0.63 - 5.7	*70 - *70	K260-18/4	735	9.7	5.7	7
0.48 - 4.3	*30 - *30	K269-18/4	955	7.9	3.9	6
0.48 - 4.3	*70 - *70	K260-18/4	955	9.7	5.7	7
0.46 - 4.16	*10 - *10	K27-18/4	1006	6.8	2.8	5
0.38 - 3.4	*10 - *10	K27-18/4	1221	6.8	2.8	5
0.30 - 2.7	*10 - *10	K27-18/4	1540	6.8	2.8	5
0.25 - 2.3	*10 - *10	K27-18/4	1833	6.8	2.8	5
0.17 - 1.5	*10 - *10	K27-18/4	2806	6.8	2.8	5

* Design-related permissible torque of transmission gear

Actuator with spur and bevel gear

Series K

Driving power
0.18 KW

Adjusting range
1:9

Output speed n ₂ at n ₁ = 1400 1/min 1/min	Output torque M ₂ Nm	Type	Gearing ratio i =	Appr. weight w motor kg	Appr. weight w/o motor kg	Dimensions Fig. no.
71 - 640	4.9 - 1.5	K23W2-18/4	6.6	7.4	3.4	9
56 - 500	6.5 - 1.9	K23W2-18/4	8.4	7.4	3.4	9
46 - 414	7.6 - 2.3	K23W2-18/4	10.2	7.4	3.4	9
36 - 327	9.6 - 2.8	K23W2-18/4	12.8	7.4	3.4	9
29 - 261	12.5 - 3.8	K22W2-18/4	16	8.1	4.1	8
22 - 202	15.4 - 4.6	K23W2-18/4	20.7	7.4	3.4	9
17 - 155	*20 - 6.3	K22W2-18/4	27	8.1	4.1	8
15 - 135	*20 - 7.2	K23W2-18/4	31.2	7.4	3.4	9
14.5 - 131	24.5 - 7.3	K239W3-18/4	32	9.3	5.3	10
13.3 - 120	*20 - 8.2	K22W2-18/4	35	8.1	4.1	8
10.5 - 94	*20 - 10	K24W2-18/4	44.6	7.5	3.5	9
8.3 - 75	*20 - 12.7	K24W2-18/4	56	7.5	3.5	9
8.3 - 75	*30 - 12.7	K239W3-18/4	56	9.3	5.3	10
6.8 - 61	*20 - 15.2	K24W2-18/4	68	7.5	3.5	9
6.5 - 58	*30 - 16.4	K239W3-18/4	72	9.3	5.3	10
5.4 - 48	*20 - 19.2	K24W2-18/4	86	7.5	3.5	9
5.3 - 48	*30 - 19.5	K249W3-18/4	88	9.3	5.3	10
4.5 - 41	*20 - *20	K24W2-18/4	103	7.5	3.5	9
3.2 - 28	*30 - *30	K249W3-18/4	151	9.3	5.3	10
3.0 - 27	*20 - *20	K24W2-18/4	157	7.5	3.5	9
2.5 - 23	*20 - *20	K25W2-18/4	185	7.5	3.5	9
2.4 - 21	*30 - *30	K249W3-18/4	196	9.3	5.3	10
2.1 - 18.7	*20 - *20	K25W2-18/4	225	7.5	3.5	9
1.97 - 17.6	*30 - *30	K259W3-18/4	238	9.4	5.4	10
1.6 - 14.8	*20 - *20	K25W2-18/4	284	7.5	3.5	9
1.4 - 13	*20 - *20	K25W2-18/4	338	7.5	3.5	9
1.15 - 10.3	*30 - *30	K259W3-18/4	407	9.4	5.4	10
0.96 - 8.7	*20 - *20	K26W2-18/4	484	7.6	3.6	9
0.9 - 7.9	*30 - *30	K259W3-18/4	529	9.4	5.4	10
0.76 - 6.9	*20 - *20	K26W2-18/4	611	7.6	3.6	9
0.73 - 6.5	*30 - *30	K269W3-18/4	643	9.4	5.4	10
0.63 - 5.7	*30 - *30	K26W2-18/4	741	7.6	3.6	9
0.50 - 4.5	*20 - *20	K26W2-18/4	935	7.6	3.6	9
0.42 - 3.8	*20 - *20	K26W2-18/4	1113	7.6	3.6	9
0.42 - 3.8	*30 - *30	K269W3-18/4	1102	9.4	5.4	10
0.33 - 2.9	*30 - *30	K269W3-18/4	1432	9.4	5.4	10
0.23 - 2.1	*20 - *20	K27W2-18/4	2011	7.6	3.6	9
0.19 - 1.72	*20 - *20	K27W2-18/4	2442	7.6	3.6	9
0.15 - 1.36	*20 - *20	K27W2-18/4	3079	7.6	3.6	9
0.13 - 1.15	*20 - *20	K27W2-18/4	3665	7.6	3.6	9
0.08 - 0.75	*20 - *20	K27W2-18/4	5611	7.6	3.6	9

* Design-related permissible torque of transmission gear

Actuator with worm gear

Series K

Driving power
0.18 KW

Adjusting range
1:9

Output speed n_2 at $n_1 = 1400$ 1/min 1/min	Output torque M_2 Nm	Type	Gearing ratio i =	Appr. weight w motor kg	Appr. weight w/o motor kg	Dimensions Fig. no.
92 - 830	2.9 - 0.87	K2S1-18/4	5	6.7	2.7	11
67 - 600	4.1 - 1.2	K2S1-18/4	7	6.7	2.7	11
47 - 420	5.4 - 1.6	K2S1-18/4	10	6.7	2.7	11
31 - 280	8.1 - 2.4	K2S1-18/4	15	6.7	2.7	11
26 - 233	8.1 - 2.4	K2S1-18/4	18	6.7	2.7	11
19 - 174	*9.2 - 2.9	K2S1-18/4	24	6.7	2.7	11
15 - 135	*10.3 - 3.2	K2S1-18/4	30	6.7	2.7	11
12 - 108	*11.4 - 4.1	K2S1-18/4	38	6.7	2.7	11
8.5 - 7.6	*10.4 - 4.5	K2S1-18/4	55	6.7	2.7	11
6.2 - 56	*7.3 - 5.1	K2S1-18/4	75	6.7	2.7	11
4.7 - 42	*7.4 - 6.7	K2S1-18/4	100	6.7	2.7	11

* Design-related permissible torque of transmission gear

Typ K2 mit freier Antriebswelle

Bild 1

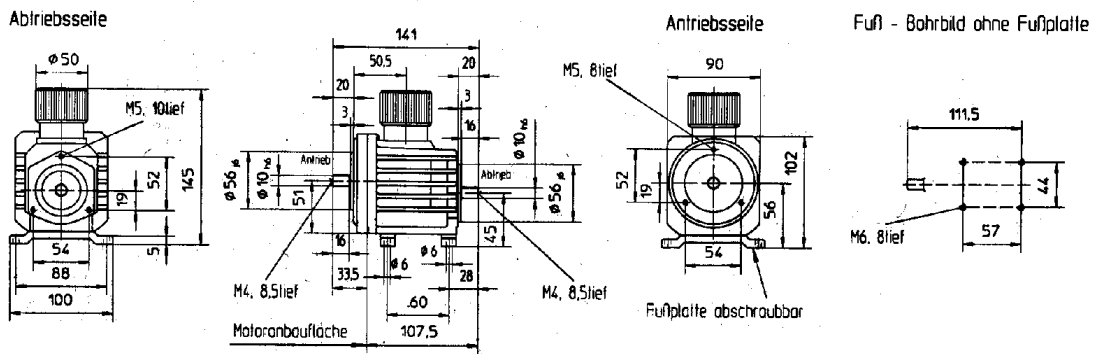

Typ K2

Bild 2

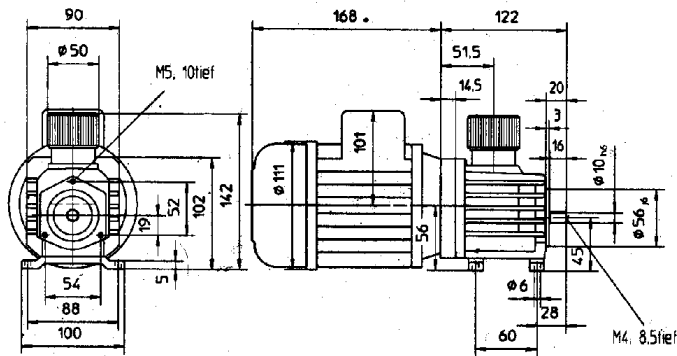

Typ K21

Bild 3

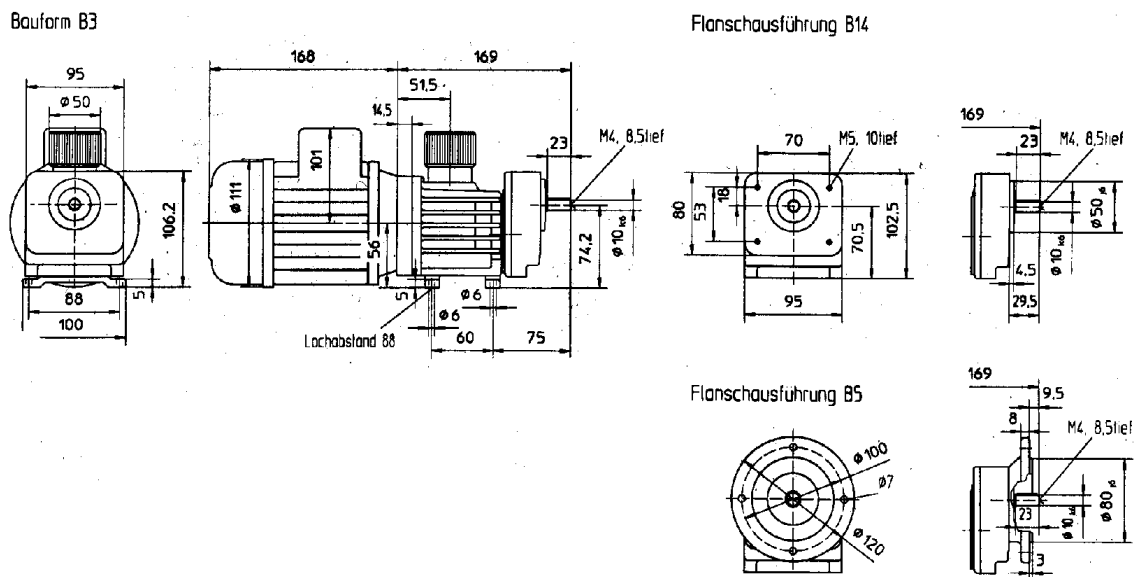

Typ K22

Bild 4

Bauform B3

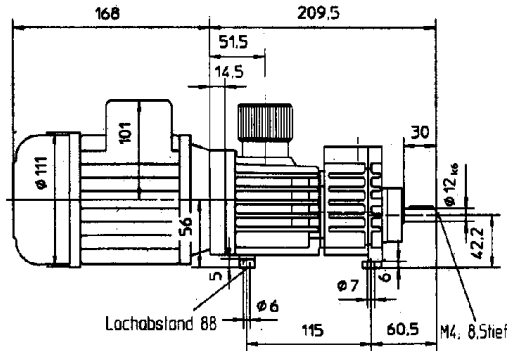
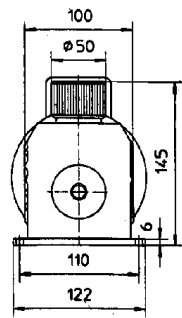

Flanschsausführung B14

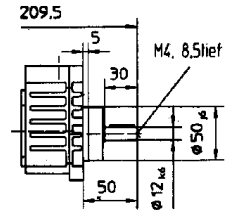
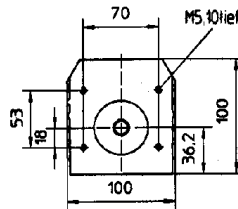

Flanschsausführung B5

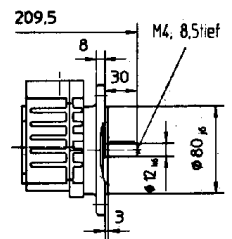
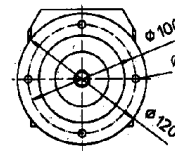

Typ K23 - K27

Bild 5

Bauform B3

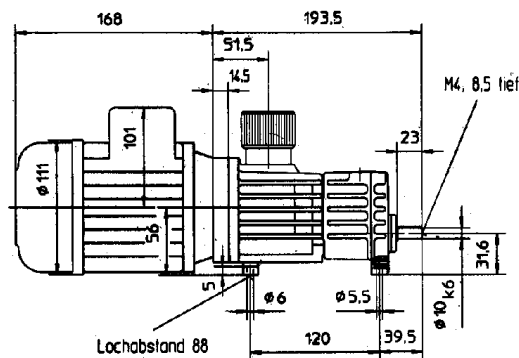
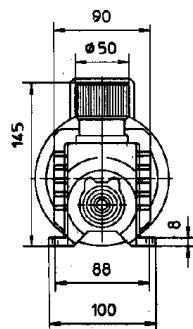

Flanschsausführung B14

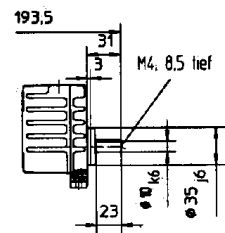
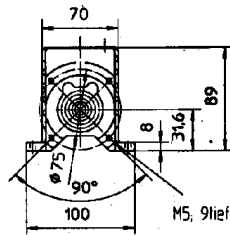

Flanschsausführung B14R

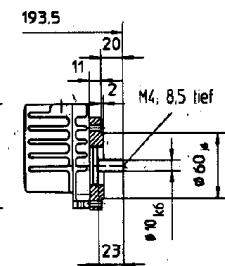
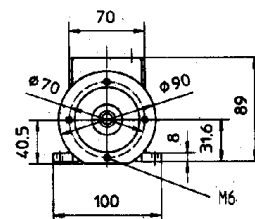

Typ K239 - K269

Bild 6

Bauform B3

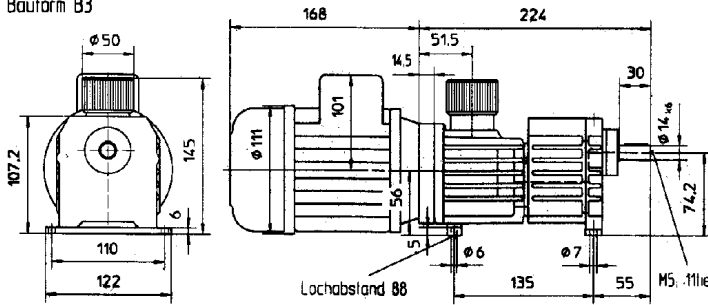

Flanschführung B14

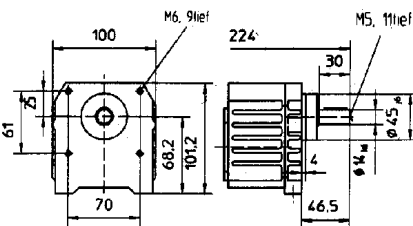

Flanschführung B5

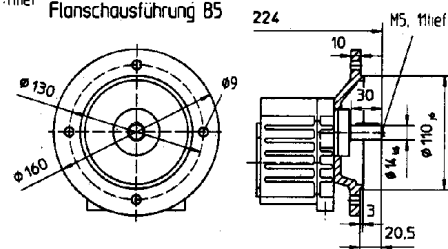

Typ K240 - K260

Bild 7

Bauform B3

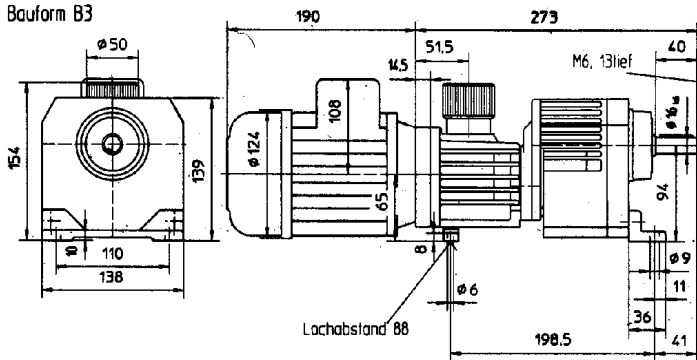

Flanschführung B14

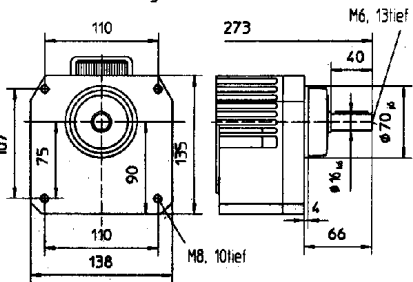

Flanschführung B5

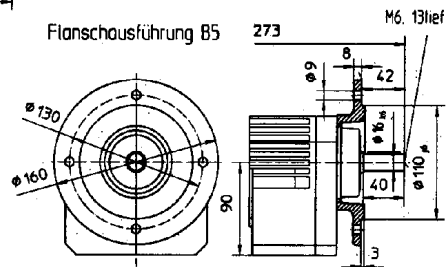

Typ K22W2

Bild 8

Bauform B3

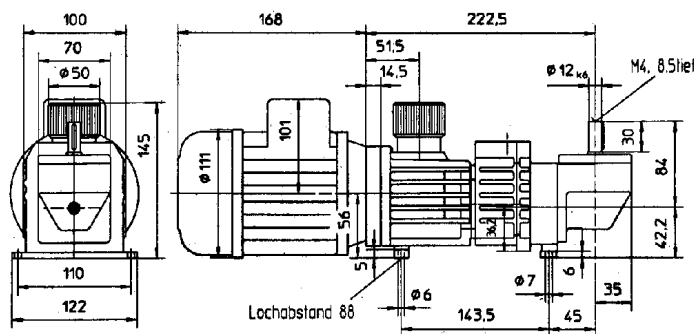

Flanschführung B14

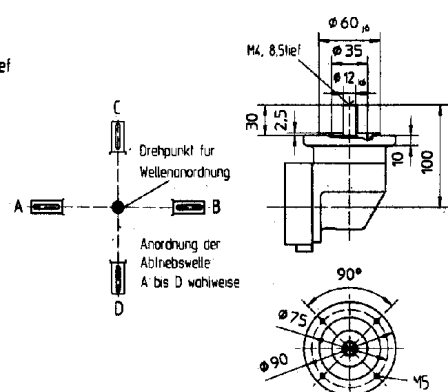

Typ K23W2 - K27W2

Bild 9

Bauform B3

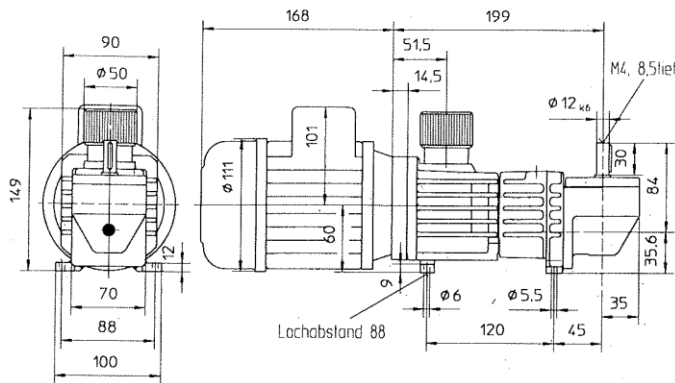

Flanschführung B14

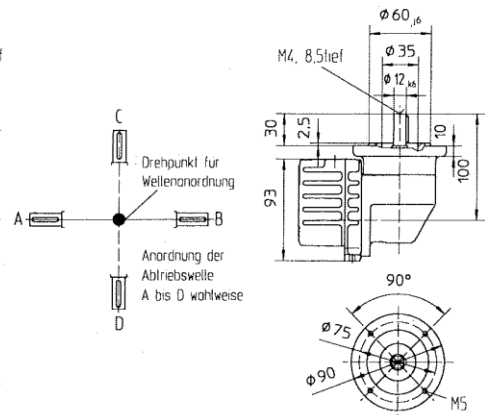

Typ K239W3 - K269W3

Bild 10

Bauform B3

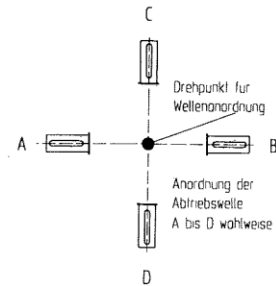
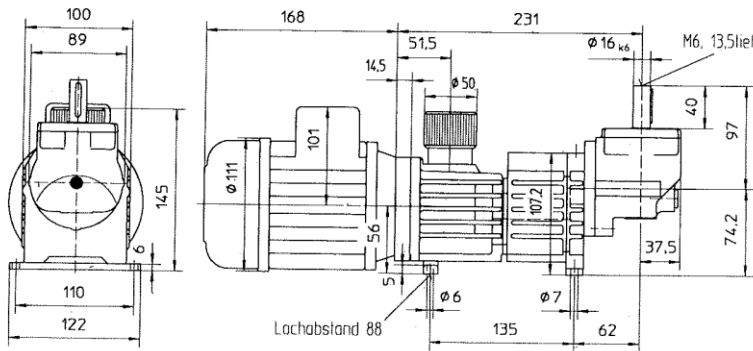

Typ K2S1

Bild 11

